

TLMG Series Level Monitors

Installation Instructions (For Grady White Boats)

The Concept: TLM uses simple and reliable sensing technology (floats) to indicate tank level in fresh or waste water applications. The sending unit is designed for tank-top installation into a 1-1/2" NPT threaded opening.

Installation, Sender: If your tank has an available 1-1/2" NPT threaded opening, apply TFE thread tape and screw the sender into it - hand tight only.

If your tank does not have an available threaded opening, cut a 2-1/2" hole with a hole saw. Press the black rubber Tank Seal™ into the hole and then press the white PVC female threaded adaptor into the Tank Seal™. Apply TFE tape and screw the sender into adaptor.

Important: Note the position of the blue dot on the threaded plug. The dot aligns with the floats and will help you position the floats AWAY from in-tank hardware, such as pumps, standpipes or the tank wall. Interference with these items may interfere with free movement of the floats, and will result in incorrect level readings.

Installation, Panel: The gasketed indicator panel fits into a 2-1/16" x 3-3/8" wall cut-out and is suitable for use in wet locations such as shower/head compartments. 2" clearance is required behind the wall. Use the attached template to assist with cut-out dimensions.

Electrical: Refer to the wire size selection chart enclosed to properly size DC power and Macerator Pump connections. Use ring terminals for #6 stud for connections to the indicator panel (supplied).

Operation: Tank level will be indicated only when "Show Level: is pressed. Level indications are as follows:

- * Tank level is below 1/4 - No level is indicated
- * Tank level is between 1/4 and 3/4 - 1/4 level is shown
- * Tank level is 3/4 or more - both 1/4 and 3/4 level are shown

Custom Length Sender: Custom length senders are available in 1" increments. Order 08-0004-XX (XX = tank depth).

Maintenance: Periodically remove and rinse the sender. Reinstall HAND TIGHT ONLY. No regular maintenance is required. Annual inspection of plumbing and electrical connections should be made.

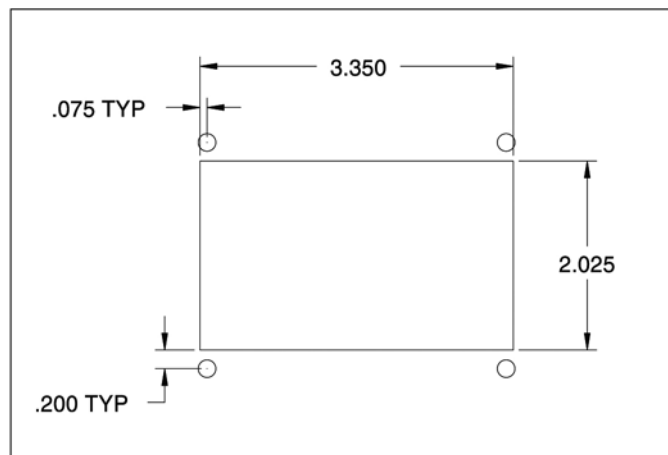
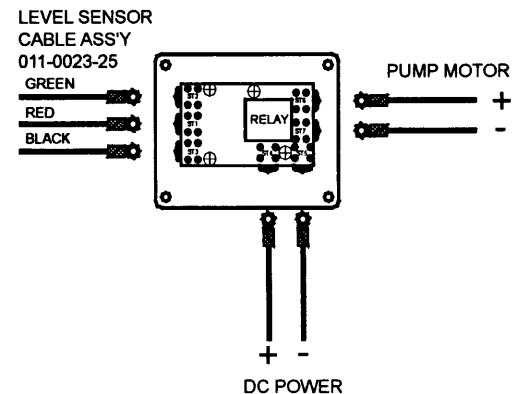

TLMG PANEL CUTOUT
(not to scale)