

# SVS Series Seacock and Strainer Combinations

## FEATURES:

- Plumbing simplified by one simple location for sea valve and strainer
- Bronze Castings
- Expanding Buna-N Plug - No valve plug freeze
- Strainer has monel filter screen and center tie rod.

**INSTALLATION:** Install valve on proper size bronze thru-hull fitting and secure to hull or butt block with (2) 3/8" bolts. Use a sealant between hull and valve flange and in accordance with project A-2 of the American Boat and Yacht Council (ABYC). Position valve so as to drain when drain plug is removed.

**OPERATION:** Loosen wingnut and turn handle vertically to open and horizontally to close. Hand-tighten wingnut each time. NOTE: While wingnut is loosened for opening or closing of valve, some slight leakage is normal, but will stop when wingnut is retightened.

**WINTERIZATION:** To properly winterize, all water must be drained from valve body, strainer, and connecting piping. First, close seacock, loosen strainer wingnut and remove wingnut, wingnut washer, and wingnut cover. Remove drain plug from valve body and from bottom of strainer. When completely drained, replace two drain plugs and tighten. Then replace wingnut cover, wingnut washer, and strainer wingnut and tighten.

**CARE:** If, after several seasons of operation the valve becomes more difficult to operate, a light lubricant may be in order. At haulout, have the valve plug removed, greased, and replaced. At the factory, #4000 Drydene Lubricant is used in initial assembly. Inspect and clean strainer parts frequently.



SVS. NO.	PIPE SIZE	HEIGHT	DIAMETER	WEIGHT
SVS-750	3/4"	10"	5-1/2"	8-1/2 LBS.
SVS-1000	1"	11-1/2"	5-1/2"	8-5/8 LBS.
SVS-1250	1-1/4"	14-1/2"	5-1/2"	9-1/2 LBS.

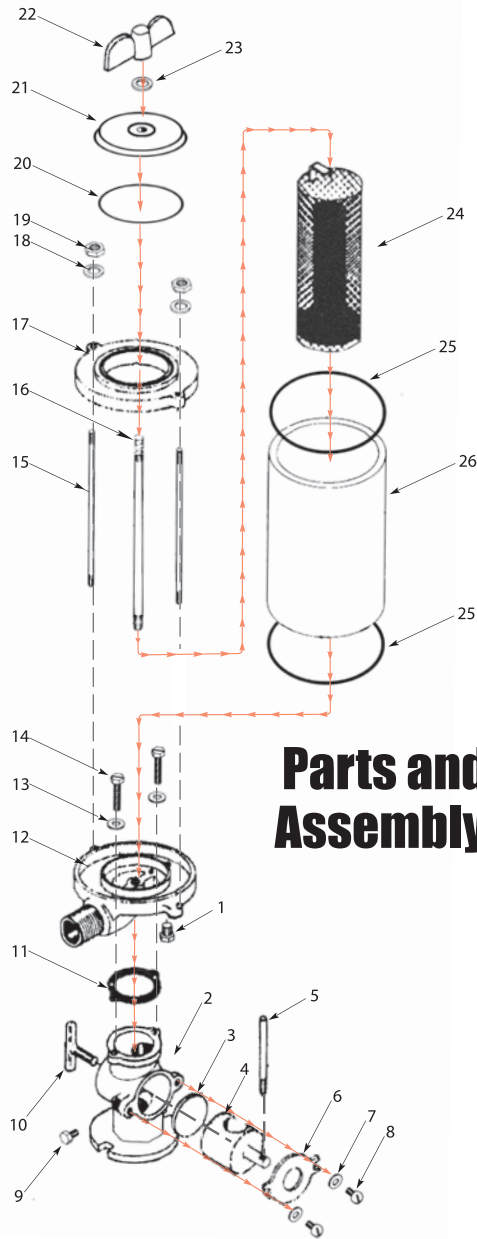

## Parts and Assembly

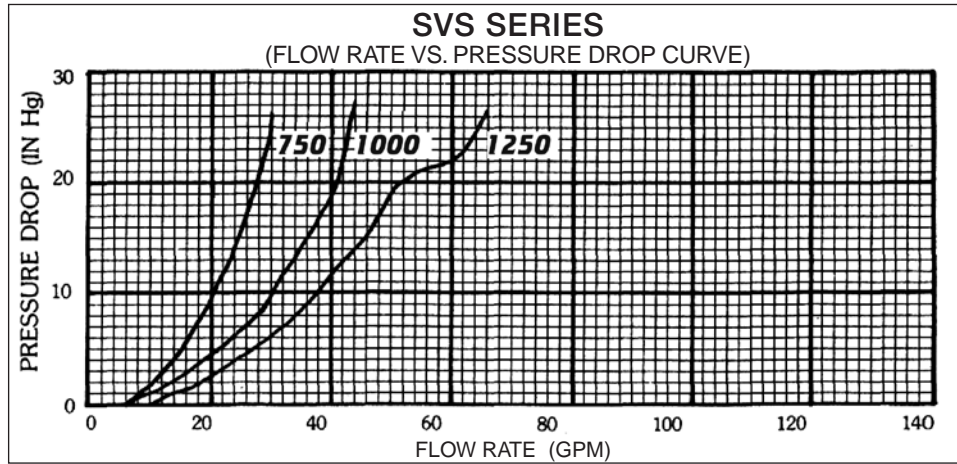

ITEM	3/4"	1"	1-1/4"	PART NAME	QTY
1	1/8-27	1/8-27	1/8-27	Drain Plug	1
2	SVS-750	SVS-1000	SVS-1250	Valve Body	1
3	SVS-103	SVS-103	SVS-1252	Disc	1
4	SVS-104	SVS-104	SVS-1254	Plug	1
5	SV-1006-A	SV-1006-A	SV-1256-A	Plug Handle	1
6	SV-101	SV-101	SV-1251	Body Cover	1
7	14 ETB	14 ETB	14 ETB	Lockwashers	2
8	1/4X1/2 HB	1/4X1/2 HB	1/4X1/2 HB	Cover Screws	2
9	1/8-27	1/8-27	1/8-27	Drain Plug	1
10	SV-752	SV-752	SV-1502	Expanding Nut	1
*11	SVS-1003	SVS-1003	SVS-1003	Body Gasket	1
12	SVS-1002	SVS-1002	SVS-1252	Strainer Base	1
13	1/4	1/4	1/4	Lockwashers	2
14	1/4x1 FM	1/4x1 FM	1/4x1 FM	Base Screws	2
15	SVS-759	SVS-1009	SVS-1259	Outside Tie Rods (NB)	2
16	SVS-758	SVS-1008	SVS-1258	Inside Tie Rods (Monel)	1
17	SVS-4	SVS-4	SVS-4	Strainer Cap	1
18	14 ETB	14 ETB	14 ETB	Lockwashers	2
19	1/4 - 20	1/4 - 20	1/4 - 20	Tie Rod Nuts	2
*20	2-232	2-232	2-232	Cap O-Ring Gasket	1
21	SVS-6A	SVS-6B	SVS-6C	Wing Nut Cover	1
22	SVS-5	SVS-5	SVS-5	Strainer Wing Nut	1
*23	500-K	500-K	500-K	Wing Nut Gasket	1
24	SVS-754	SS-1004	SS-1254	Screen Assembly	1
*25	#8R SET	#8R SET	#8R SET	Cylinder Gaskets	2
26	SVS-756	SVS-1006	SVS-1257	Cylinder	1
	*SVS	SVS	SVS	SVS Repair Kit	

© 1999 GROCO MECHANICAL LABORATORIES, INC. ALL RIGHTS RESERVED.