

# Installation, Operation and Maintenance Instructions for PWR DC Models

# GROCO®

MODEL: PWR DC Models 12 V & 24V Paragon Water Pressure System

This package includes:

- PWR Paragon Water Pressure System
- WSB-750 Inlet Strainer (*not shown*)
- 17-0017-01 Remote Plumbing Kit (*not shown*)

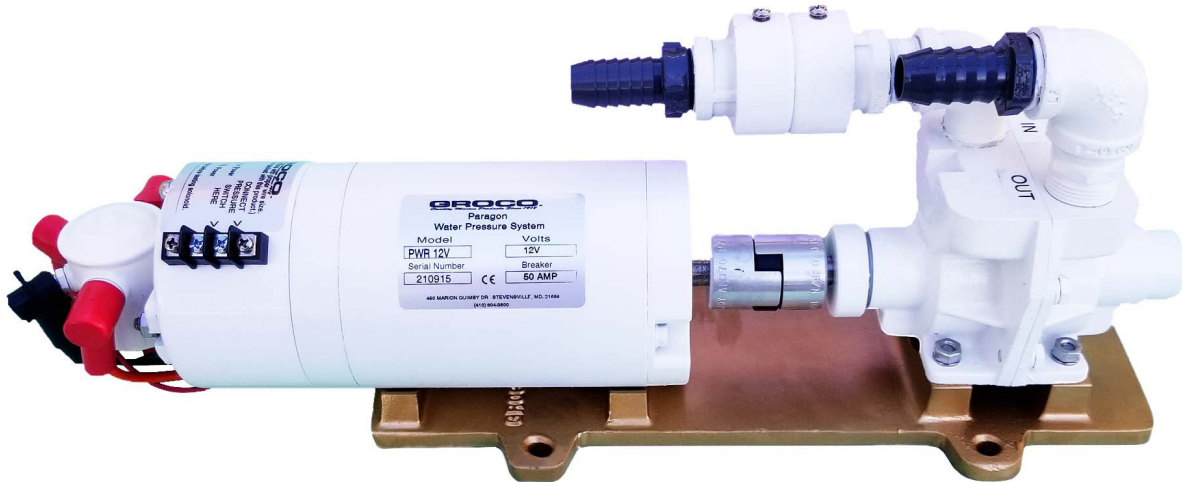

- PWR Paragon Water Pressure System

## INSTALLATION

**Installation Notes:** Motor and circuitry are not waterproof. Install PWR in a dry and well-ventilated location not more than 10-feet above the water supply. If the inlet is 'flooded' (at or below the water supply), PWR can be installed in any position. If PWR must self-prime, orientation must be with plumbing connections at the top.

Mount PWR to a sturdy platform using the 4 mount feet provided.

*Installation, cont. →*

## INSTALLATION (CONTINUED)

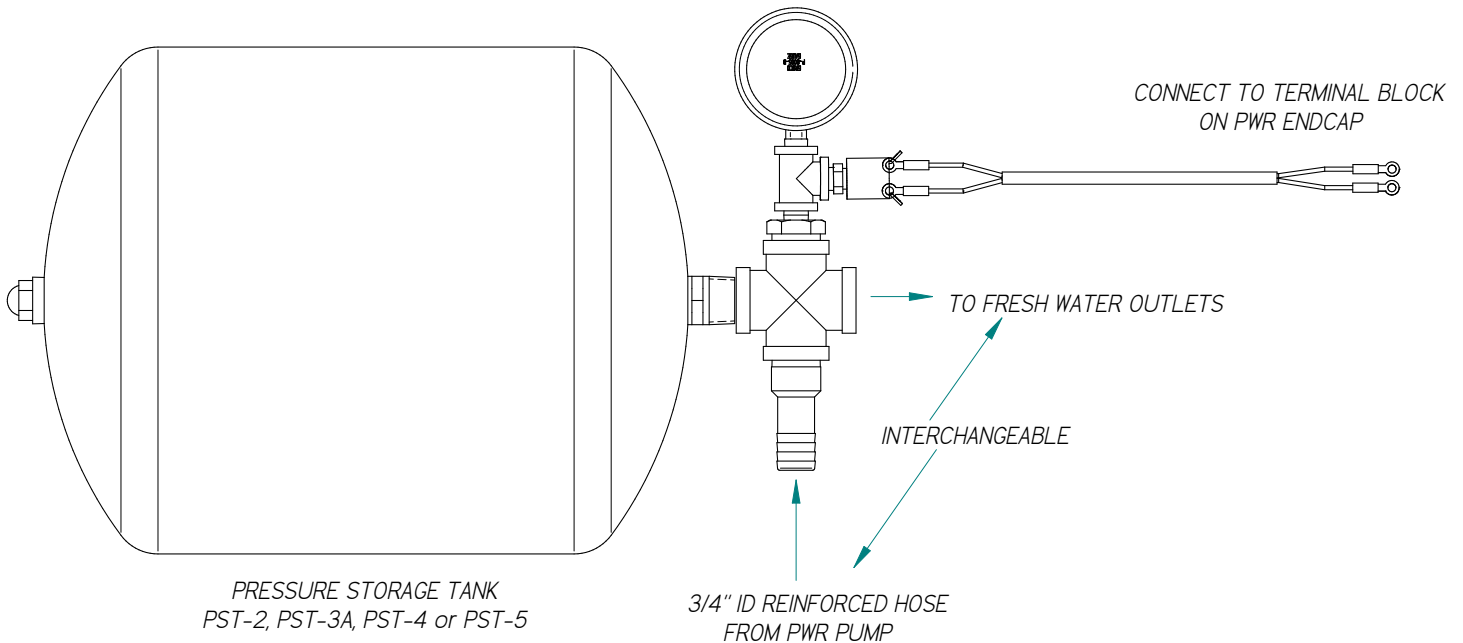

17-0017-01  
 Plumbing Kit

**Plumbing:** Fasten 17-0017-01 plumbing kit to the Pressure Storage Tank (PST) with the pressure switch on the system side (not the pump side). Plumbing between the supply tank and PWR must be 3/4" ID heavily reinforced hose. Install the WSB strainer in this line where it can be inspected and serviced, and drained for winterization.

Plumbing between PWR and the PST must also be 3/4" ID heavily reinforced hose. Plumbing after the PST may be reduced.

To aid initial priming pour water into the pump inlet.

We DO NOT recommend the use of water filters or purifiers as they may reduce system pressure and flow. If you decide to use a filter or purifier it must be installed AFTER the PST Pressure Storage Tank has been installed.

**Pressure Storage Tank (PST):** A PST must be used. Suitable sizes are PST-2, PST-3A, PST-4 or PST-5 or equal; larger tanks will reduce pump cycling. **IMPORTANT - BEFORE APPLYING POWER**, check and adjust PST pressure to 28-30 PSI (there is a Schrader valve at the end of the PST for this purpose).

**Pressure Switch:** A 10-foot wire harness is provided to connect the pressure switch on 17-0017-01 plumbing kit to the terminal block on PWR. There is no polarity for this connection.

**Electrical:** Proper wire size is essential. Refer to the wire size selection chart supplied, and provide PWR with a dedicated circuit breaker (50-amp for PWR 12V or 30-amp for PWR 24V). Connect +DC to the solenoid terminal with the red tag. Connect -DC to the bronze stud directly below the solenoid.

Do not connect PWR to the vessel bonding system.

## OPERATION

**Start-up:** Before applying power open all faucets and showers half-way. When power is applied the pump will run and prime itself within 30-seconds. As water flows smoothly from each faucet or shower, shut it off. When all outlets are off, PWR will pressurize the system and shut off. Note – it may take several minutes to fill water heaters and the PST.

If PWR does not self-prime, the dry tank protection system will shut the pump off. If this happens, turn off power at the circuit breaker, check for loose hoses or clamps, add water to the pump inlet and then reapply power.

**Dry Tank Protection:** Either of the following conditions is considered to be a dry tank and will shut off PWR pump:

1. If the ‘NOFLO’ module (patented) does not detect water for 30-seconds;

Note: Water from some R/O systems or purification systems may not be sensed by NOFLO. In this instance you may experience a ‘nuisance shutdown’ (NOFLO turns off PWR even if water is present). On top of NOFLO are 2 screws and a jumper wire that is connected to only one of the screws. If you experience ‘nuisance shutdowns’ NOFLO can be disabled by connecting the jumper. The 10-minute timer will still provide dry tank protection.

2. If PWR motor runs continuously for more than 10-minutes. Note: though you may be continuously drawing water, the motor stops (the timer is reset) each time the system reaches pressure.

## MAINTENANCE

**Winterization:** Freezing may damage the pump and plumbing. Winterize the system by opening showers and faucets and allowing PWR to pump the supply tank dry. Disconnect power, then disconnect hoses connected to PWR inlet and outlet. Remove WSB-750 sight glass. Pour a small amount of potable alcohol into the pump. **DO NOT USE ANTIFREEZE – ANTIFREEZE IS POISONOUS.**

### Maintenance:

**Monthly** (or as needed) – check and clean WSB-750 strainer

**Annually** (or as needed) – check and adjust PST pressure to 28-30 PSI. Do this with no water pressure present.

### Service Notes:

- Adjustable pressure switch S-21 may be substituted, but due to the inherent spark hazard, 69A or 69WFC switches must not be used on gasoline-powered vessels.
- Some PWR parts are interchangeable with PSR models.

Installation, Operation and Maintenance Instructions for  
**PWR DC Models**



Exploded View - PWR Paragon Water Pressure System

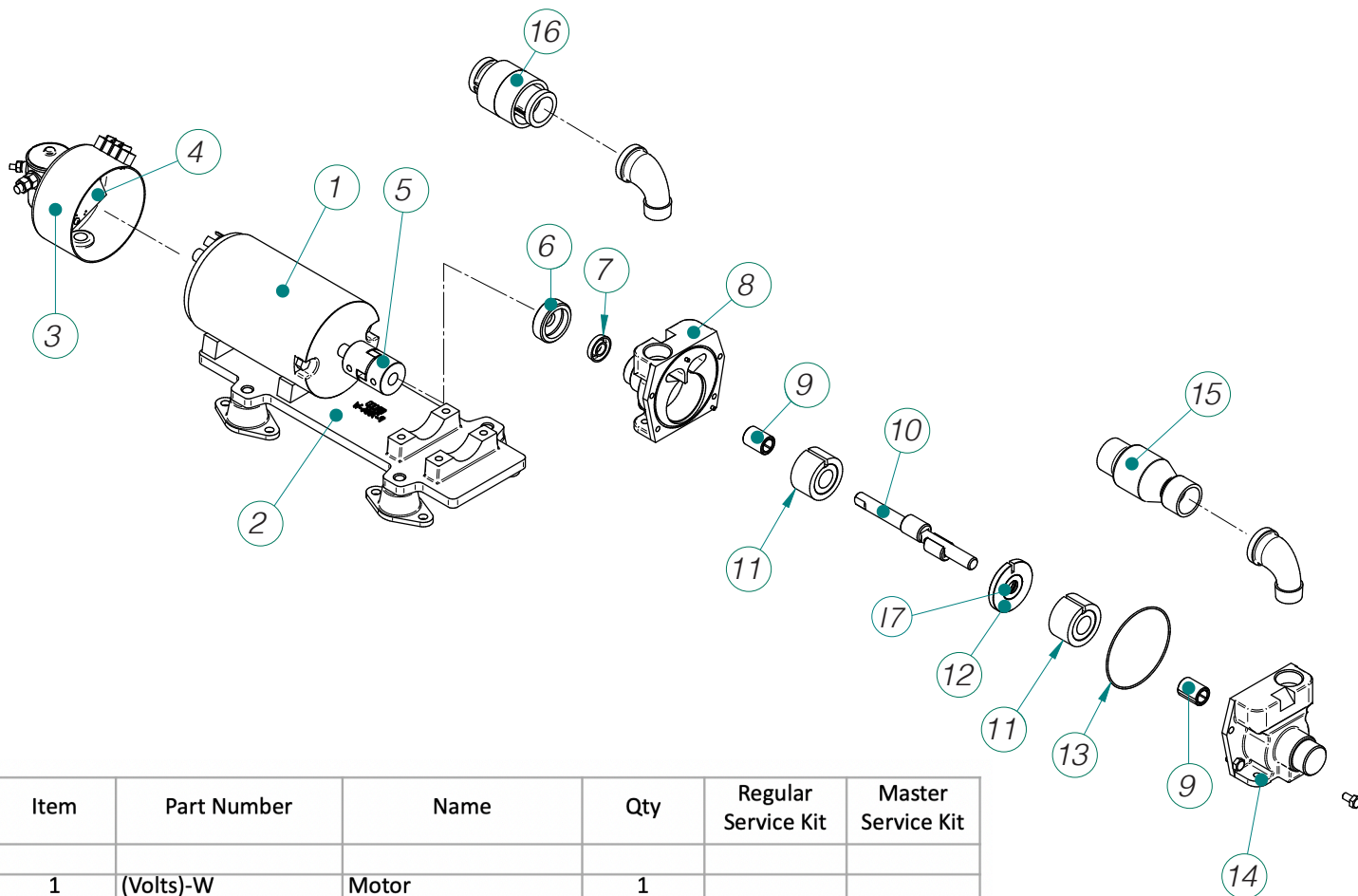

Item	Part Number	Name	Qty	Regular Service Kit	Master Service Kit
1	(Volts)-W	Motor	1		
2	P-7004-W	Base	1		
3 & 4	P-6001-W (Volts)	Control Assy	1		
4	012-0022-01	PCB	1		
5	P-7005	Coupling	1		
		Coupling Spyder	1		x
6	P-9020-C	Cap	1		
7	P-9015	Seal	2	x	x
8	P-9001-B	Rear Housing	1		
9	P-9009	Bearing	2		
10	P-9003/4 Assy	Shaft & Eccentrics	1		
11	P-9014 SET	Impellers	1		x
12	P-9006	Seperator	1		
17	P-9006-A	TFE Washers	2	x	x
13	2-042	O-Ring	1	x	x
13	2-041	O-Ring before 1986	1	x	x
14	P-9002	Front Housing	1		
15	CV-75-P	Check Valve	1		
16	NOFLO7500	Dry Tank Protection	1		
NS	P-8005-B	Gauge	1		
Notes:	P-9001-B and P-9002 are sold as a set				
	W motor does not fit PSR base. Replace motor and base together				

© 2022 GROSS MECHANICAL LABORATORIES; ALL RIGHTS RESERVED