

ZDS Series Type-III MSD Installation, Operation, and Maintenance

THE CONCEPT: ZDS series is a self-contained Type-III Waste Management System that receives, holds, deodorizes, and discharges waste from one or more onboard toilets. Operation is quiet, efficient (17 GPM macerator pump is inside the holding tank) and reliable with state of the art touch-pad control.

HOLDING TANK INSTALLATION: Refer to Figure-1. Mount the tank in a sturdy location that provides room for routine cleaning and service. Secure the tank with the straps provided to prevent tank movement while underway.

PLUMBING: Double-clamp hose connections. Use Teflon® thread tape for pipe connections.

*Level Sender: Screw in hand-tight only. Orient the blue mark AWAY from the center of the tank.

*Suction Standpipe: The 1-1/2" male pipe threaded fitting is for connection to a deck fitting, and is used for suction pump-out.

*Vented Loop: Use a 1-1/2" vented loop (GROCO HVL-1500) between the toilet and the tank, and a 3/4" vented loop (HVL-750) between the tank and overboard. Vented loops should be at least 12" higher than the outside waterline. Remember the relationship between the waterline and the holding tank will change with boat movement.

VENTING: Efficient venting is essential for proper pump operation. Vent to both port and starboard as shown in the sample installation drawing. Assure that the vent line(s) run continuously downhill from the hull to the holding tank, and that there are no sags or traps in the vent hoses.

IMPORTANT: A clogged vent will prevent efficient Sweettank® operation and may result in minor pressurization of the holding tank by the air injector pump.

SWEETANK®: GROCO MSDs include Sweettank®, a patented odor elimination system that requires no chemicals or filters.

Install the air injection pump box anywhere in the bilge or engine room to a dry solid surface with the Velcro® strips provided. Connect the air pump to the holding tank with the clear hose provided. The tank connection is a "push-to-lock" fitting on top of the tank - it is **IMPORTANT** to push the clear hose firmly into this fitting to assure proper air flow.

INDICATOR PANEL: The indicator panel fits into a 3.35" x 2.025" cutout. The touch-pad is waterproof, but the foam gasket must be in place to provide a proper seal for wet locations such as in a combination head/shower.

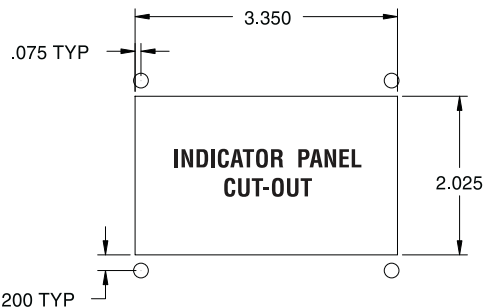

ELECTRICAL: Refer to the wire size selection chart (enclosed) for the proper wire size for your installation, and remember that wire size will vary with distance from power source. The holding tank components receive power from the indicator panel, so the entire distance from the power source to the panel to the holding tank AND BACK must be considered when selecting wire size.

*Indicator Panel - Protect the MSD system with a dedicated 25-amp breaker. Make electrical connections to the indicator panel as shown in Figure-2.

*Macerator Pump - Connect positive and negative power between the indicator panel and the macerator pump terminal block as shown in Figure-2. Observe proper polarity.

*Level Sender - A 25-foot cable is supplied for connecting the tank-mounted level sender to the indicator panel as shown in Figure-2. Observe proper connection positions for black, red and green wires.

* Sweettank® - The air injector pump uses 3-watts of power, so it may be left on continuously if the boat has a charging system to maintain full battery charge. Alternately, the air pump may be switched off when the boat is not in use. Power for the air pump may be shared with any 12VDC system that is on whenever the boat is in use.

Wire from the breaker panel directly to the air pump terminal block. A 1/2-amp fuse is provided for air pump protection.

OPERATION: Apply power to the MSD system at the power distribution panel.

Level Indicator - Level indication will be illuminated continuously if level is 1/4 full or more. Optionally, if you want to show level only when "show level" is depressed, cut the wire jumper (marked with a twisted wire) on the back of the circuit board.



Macerator Pump - The macerator pump will operate only while the "Pump Out" button is depressed. Release the button when you hear the pump pumping air.

MAINTENANCE: Level Sender - Unscrew and rinse the level floats at least annually.

Sweettank Bubbler - Unscrew and rinse the bubbler at least annually. The sections of the bubbler unscrew for thorough cleaning. Use a stiff bristled brush to clean sections.

WINTERIZATION: Fill the holding tank to 75% with clean water and then pump out. The small amount of water left in the tank will not damage the components if it freezes. Unscrew, remove and rinse the level sender and the bubbler. Reinstall both components.

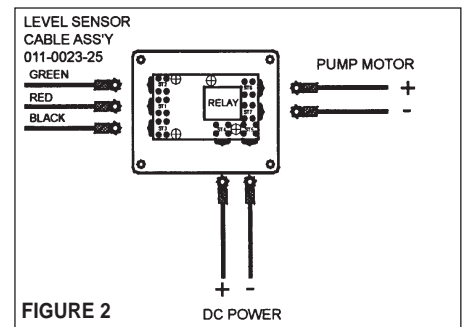
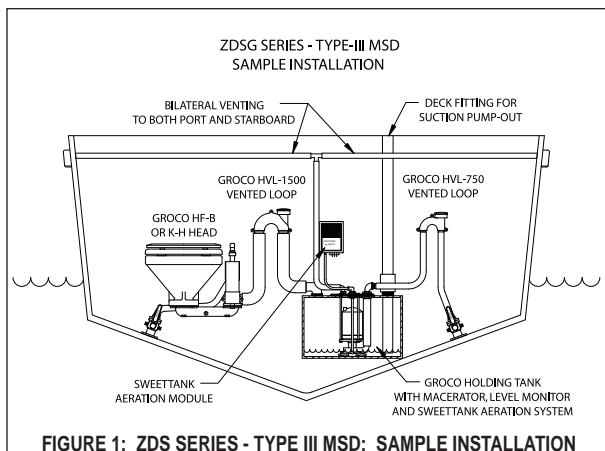

FIGURE 2
It is illegal to discharge untreated waste overboard. Consult local regulations governing overboard discharge. Restrictions vary with geographic location.

© 1999 GROCO MECHANICAL LABORATORIES, INC. ALL RIGHTS RESERVED.