

CP-20-BB / CP-20-BBWA / CP-20-BBC Pumps

Installation, Operation, and Maintenance

The Concept: GROCO CP-20-series pumps are efficient centrifugal pumps designed for use in hot or cold water circulating systems in automotive, industrial, or marine and RV applications.

Installation: Install the pump in a location that will provide generous air flow for motor cooling. Fasten securely to the mount platform with four (4) 1/4" fasteners (not supplied).

Electrical: Proper wire size is essential for proper motor and pump performance. Make power connections (orange is + positive) that assure no more than a 3% voltage drop.

Plumbing: Make plumbing connections with pipe, hose, or pipe-to-hose adaptors.

Double clamp hose connections and use TFE tape on threaded connections.

Bends in hose or pipe connections will restrict pump flow. Plan the installation so as to minimize bends. Use full-flow fittings when possible. Contact GROCO for bronze pipe-to-hose adaptors.

CP-20 series pumps require a flooded inlet. Assure that the pump is supplied with a continuous flow of water.

Maintenance: No regular maintenance is required



CP-20-BB
Inlet and Outlet for 1" ID Hose



CP-20-BBWA Inlet for 1/2" NPT,
Outlet for 1/2" NPT or 1" ID Hose



CP-20-BBC Inlet for 3/4" NPT,
Outlet for 1" ID Hose

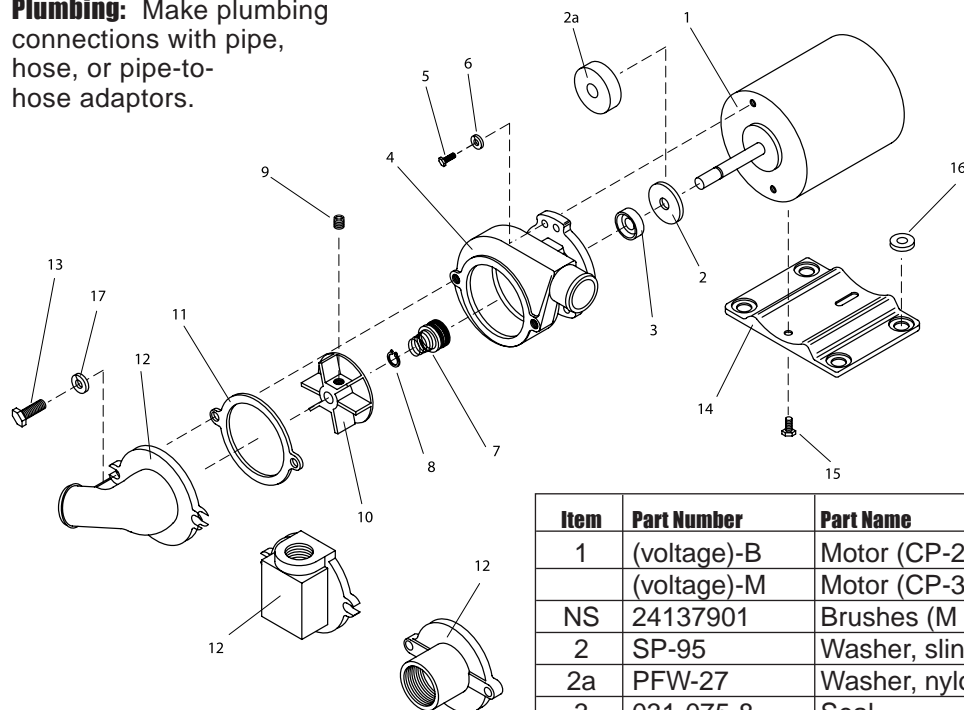

Item	Part Number	Part Name	Qty	Service Kit
1	(voltage)-B	Motor (CP-20-BB Series)	1	
	(voltage)-M	Motor (CP-30-BB Series)	1	
NS	24137901	Brushes (M series)	1	
2	SP-95	Washer, slinger (before 070401)	1	
2a	PFW-27	Washer, nylon (after 070401)	1	
3	031-075-8	Seal	1	*
4	CP-20-BB	Housing	1	
5	1032X12HS	Screw	2	
6	10SS	Lockwasher	2	
7	69026	Seal Assy	1	*
8	Snap Ring-1	Snap Ring	1	*
9	14X14SET	Set Screw	1	
10	CP-55	Impeller & Set Screw	1	
11	CP-56	Gasket	1	*
12	BB-79	Cover (CP-20-BB)	1	
	WS-2501	Cover (CP-20-BBWA)	1	
	CP-58-H	Cover (CP-20-BBC)	1	
13	1420X34HS	Screw	2	
14	B-200-P	Base	1	
15	1032X12HST	Screw	2	
16	B-200-G	Grommet Set (4)	1	
17	14SS	Lockwasher	2	
	P-2	SERVICE KIT		*