

# GROCO®

## C-50 AND C-70 DECK WASH KITS

C-50 and C-70 Deck Wash Kits are completely assembled and water tested salt water washdown systems which provide pressurized water on demand, for deck or anchor wash, or both if multiple washdown locations are required.

Deck wash kits include all necessary hardware, except for electrical wiring and garden hose.

Typical installation performance is shown below. The chart shows operation through 50 feet of 1/2" I.D. garden hose and the PGN-50 Nozzle, which is included.

	MAX GPM	PSI RANGE	MAX AMPS @ 12V	FUSE
C-50	5.0	15-35	17	20
C-70	6.5	20-40	23	25

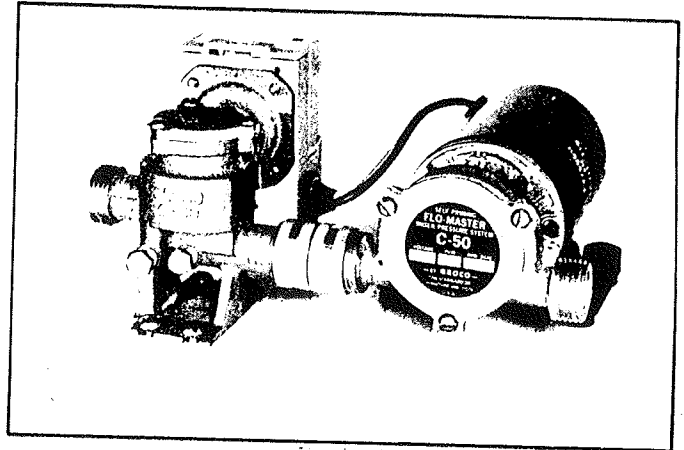

C-50 KIT

### FEATURES

- ✓ C-50 includes the SPO-30-N vane pump *12V-F*
- ✓ C-70 includes the SPO-40-N vane pump *12V-R*
- ✓ Pumps are self-priming to 24" and are coupled directly to a combination check valve/pressure switch assembly, and mounted on a ready to install mount board
- ✓ P-9021 In-line check is included to maintain system prime, even while underway
- ✓ PGN-50 Salt water nozzle is included
- ✓ May be coupled to MX2 or MX3 for multi location washdown (anchor wash forward and deck wash aft)

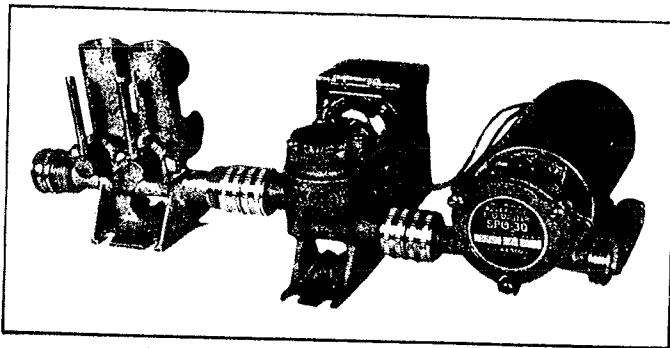

C-50 KIT WITH MX2 MANIFOLD

(Manifold may be directly coupled or remotely mounted)

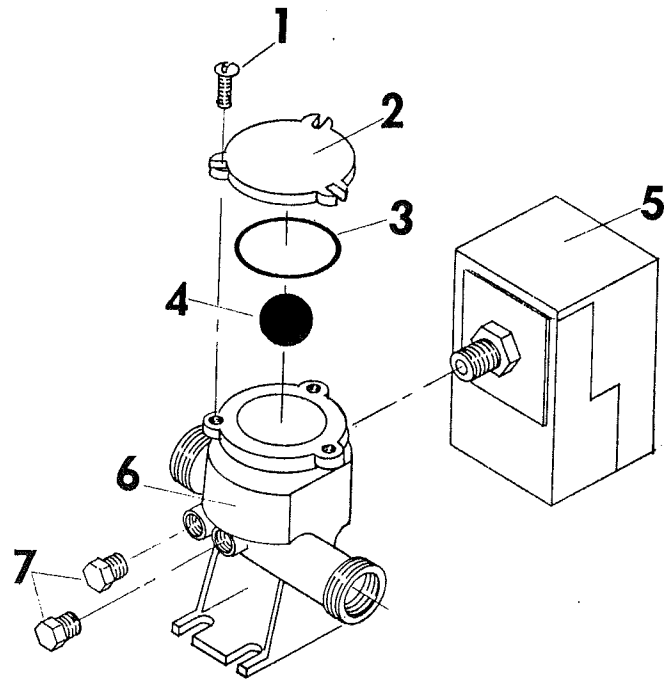

### C-50 PARTS LIST

ITEM	PART NO.	PART NAME	QTY.
1	10-24 x 1/2 RB	Screw	3
2	C 51	Cover	1
3	2 122	O Ring	1
4	HT 56	Check Ball	1
5	69 A	Pressure Switch	1
6	C 50 A	Check Valve Body	1
7	1/8 - 27 1B3	Drain Plugs	2

