

BVS Series - Seacock/Strainer Combination

Installation, Operation, and Maintenance

Installation: Thread the seacock portion onto an appropriately sized bronze thru-hull fitting. You may need to cut down the length of the thru-hull so that it does not bottom out inside the seacock before proper compression of the hull and backing block has been achieved.

Use marine grade caulking between the seacock flange and the backing block, and between the thru-hull fitting flange and the hull.

Orient the seacock so as to provide unobstructed access to the seacock handle, assuring that full 90-degree movement of the handle is possible. (To simplify plumbing hook-up the strainer head may be rotated in 90-degree increments after the seacock has been secured).

Bolt the seacock securely to the backing block with stainless steel bolts.

Connect the seacock to the boat's bonding system with 14-gauge wire and a ring connector. A bonding screw bolt is provided on the seacock flange for this purpose.

The BVS model number identifies the NPT pipe size that the strainer head is threaded (for example, BVS-750 means the strainer outlet is 3/4 NPT).

Select a pipe-to-hose adaptor that matches the threaded strainer head and that also matches the hose size you will use to plumb

the rest of the system. Full flow and standard flow, straight and 90-degree fittings are available. (See attached information sheet). Apply TFE thread tape to threaded NPT connections, and double-clip all hose connections.

Seacock Operation: Rotate the handle to the mechanical stop in the vertical position to open the seacock. Rotate the handle to the mechanical stop in the horizontal position to close the seacock.

The square hole in the handle (after 011001) is for use with a ratchet handle, and is for the purpose of easing valve activation.

Strainer Operation: Unscrew the threaded strainer cap to inspect or service the filter basket. Although hand-tight is sufficient for a good O-ring seal, the cap has three (3) holes for the use of GROCO SW-2531 spanner wrench if additional tightening is desired, or if the cap is difficult to break loose after an extended time.

Maintenance: Inspect and clean the filter basket frequently. Apply silicon based or Teflon based waterproof grease to the strainer cap threads and O-ring to ease loosening the cap for the next inspection.

BVS is designed for in-field serviceability. If replacement of internal valve parts is ever required, the valve lock nut located at the bottom of the strainer (top of the valve) may

be removable by first removing the set screws that prevent it from turning. Once the set screws have been removed, access to the valve ball and seats is possible.

Lubricate the threads and O-ring with silicon or Teflon grease before re-assembly.

The stem seals are accessible by removing the handle and unscrewing the brass nut. Pull the stem straight out for access to the stem seals.

Lubrication: BVS seacocks are fitted with one drain plug and one zerk fitting. The zerk serves as an additional drain plug but also provides for the injection of GROCO U-LUBE lubricant into the space between the ball and the valve body. U-LUBE (available in 3-oz or 14-oz tubes) is specially formulated for ball valves to lubricate wear parts and to discourage the accumulation of nuisance marine growth.

IMPORTANT - Inject U-LUBE only with the valve in the open position. Remove the drain plug to let the air or water out, and so you can visually determine when the valve is full of U-LUBE grease. Inject U-LUBE with a standard grease gun through the zerk fitting. When U-LUBE appears at the drain plug port, stop pumping. Replace and securely tighten the drain plug.

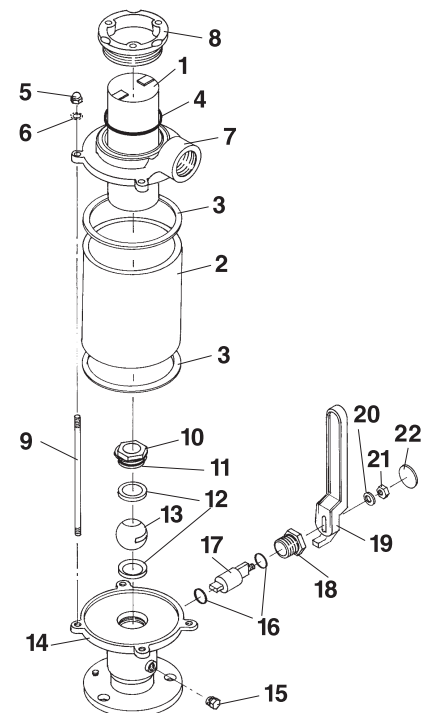

ITEM	PART NAME	QTY	BVS-750	BVS-1000	BVS-1250	BVS-1500
1	Filter Basket, Stainless Steel	1	SSS-754	SSS-1004	SSS-1254	SSS-1504
	Filter Basket, Monel (optional)	1	SS-754	SS-1004	SS-1254	SS-1504
2	Sight Glass	1	S-70-A	SVS-1006	SVS-1257	S-88
• 3	Gasket	2	#9R	#8R	#8R	#10R
• 4	O-Ring	1	2-144	2-151	2-151	2-238
5	Cap Nut	4	1420CS	1420CS	1420CS	1420CS
6	Lockwasher	4	14SS	14SS	14SS	14SS
7	Strainer Top	1	SS-751	SS-1001	SS-1251	SS-1501
8	Strainer Cap	1	SS-502-B	SS-1002-B	SS-1002-B	ARG-1501-B
9	Tie Rod	4	S-73-C	SVS-1009	SVS-1259	S-73-B
10	Valve Lock Nut	1	BVS-752	BVS-1002	BVS-1252	BVS-1502
11	O-Ring	1	2-122	2-127	2-135	2-140
12	Ball Seat	2	BV-756	BV-1006	BV-1256	BV-1506
13	Ball	1	BV-754	BV-1004	BV-1254	BV-1504
14	Valve Body	1	BVS-750-B	BVS-1000-B	BVS-1250-B	BVS-1500-B
15	Drain Plug	2	1827HB	1827HB	1827HB	1827HB
• 16	Driver Seal	2	1-015	1-017	1-017	1-116
17	Driver	1	BVS-751-A	BVS-1001-A	BVS-1251-A	BVS-1501-A
18	Driver Nut	1	BV-503-A	BV-1003-A	BV-1003-A	BV-1503-A
19	Handle	1	BV-508	BV-1008	BV-1008	BV-1508
20	Washer	1	14FS	14FS	14FS	38FS
21	Lock Nut	1	1228X38HS and 14SS	1420X12HS and 14SS	1420X12HS and 14SS	3816X15HS and 38SS
22	Cap	1	PFW-10	PFW-11	PFW-11	PFW-12
•	Service Kit		BVS-1	BVS-2	BVS-2	BVS-3

© 1999 GROCO MECHANICAL LABORATORIES, INC. ALL RIGHTS RESERVED.