

155 Series Waste Macerator Pumps Installation, Operation, and Maintenance

THE CONCEPT: Between 1980 and 1999 GROCO Macerator Pumps were offered in four different models. MPS-600 and MPS-720 were submersible models, and MPT-600 and MPT-720 were tank-top models.

Our experience in manufacturing waste-handling equipment has brought us to the introduction of 155-Series pumps, which combines all the best features of all previous models into a single submersible model, offered in lengths (1-inch increments) to fit any tank depth from 9-inches to 36-inches.

INSTALLATION NOTE: If your purchase of a 155-Series macerator pump is for a new installation you must order GROCO #MP Hardware.

If your purchase of a 155-Series pump is to replace one of the previously made GROCO macerator pumps (MPS-600, MPS-720, MPT-600 or MPT-720), 155-Series will fit the same tank mounting.

Early MPT and MPS series pumps had a circular flange and mount pattern. If you are replacing a pump with a circular flange and mount pattern, the six plastic plugs on the 155-Series pump flange are to be removed; the vacated holes will align with the old circular flange mount pattern.

INSTALLATION: For new installations use the template attached to mark the location of the mounting holes on the top of the tank, or use the gasket to mark hole locations.

Note that there are two holes marked on the template that are not on the gasket. These are for the two (2) flat-head screws that hold the ring to the tank and are shown as concentric circles on the template.

Drill fourteen (14) holes, 5/16" diameter plus the two (2) countersinks and one notch (clearance for the discharge hose) as shown on the template.

Remove twelve (12) hex nuts, one of the square gaskets, and two (2) flat-head screws from the ring.

With one square gasket remaining on the ring insert the ring into the 5-3/4" x 5-3/4" hole cut into the tank top. Position the ring so the twelve bolts align with the holes in the tank top.

Pull the ring against the under-side of the tank top so the twelve bolts come up through the tank top. Hold the ring in place by screwing two flat head screws through the countersunk tank top holes and into the ring. Align the second square gasket on the top side of the tank around the bolts protruding through the tank.

Place the 155-Series Macerator Pump onto the tank with the discharge hose aligned with the 1-1/4" x 3/8" notch in the tank top. Secure the pump flange against the tank with the plastic flat washers and hex nuts supplied.

VENTING TO ATMOSPHERE: Safety and proper macerator pump operation depend upon proper tank venting. It is absolutely essential that the holding tank be vented to outside the vessel. A chromed thru-hull vent fitting is included in MP Hardware for this purpose. Use 5/8" ID non-collapsible hose in a continuous uphill run to the thru-hull vent.

OVERBOARD DISCHARGE: The direct overboard discharge of untreated waste is unlawful in most areas. Consult local regulations and restrictions before plumbing your macerator pump for overboard discharge.

Regulations will change with geographic location.

VENTED LOOPS: If your macerator pump is plumbed for overboard discharge, a 3/4" vented loop is required between the pump and the overboard discharge point. GROCO #HVL-750 is ideal for this purpose.

PLUMBING: Use 3/4" ID reinforced hose designed for waste service to plumb the 155-Series pump discharge to HVL-750 Vented Loop, and to its ultimate discharge point. Double-clamp hose connections.

ELECTRICAL REQUIREMENTS:

Proper wire size selection is essential for safe and efficient pump operation. Refer to the wire size selection chart enclosed.

Protect 12V DC 155-Series pumps with a 25-amp circuit breaker (10 amps for 24V or 32V pumps).

LEVEL MONITOR:

End surprises with a GROCO TLM Series Level Monitor (refer to the sample installation). TLM sending unit screws into any 1-1/2" NPT threaded tank top opening, and uses simple but reliable technology to tell you when it's time to have the tank pumped out.

The Operator Panel includes connections for operating the 155-Series Macerator Pump, and can be installed in wet areas such as combination shower/head compartments.

TLM is offered in lengths (one-inch increments) to suit your tank depth. For example, for tanks 10" deep specify TLM-10. Installation hardware and cabling is included.

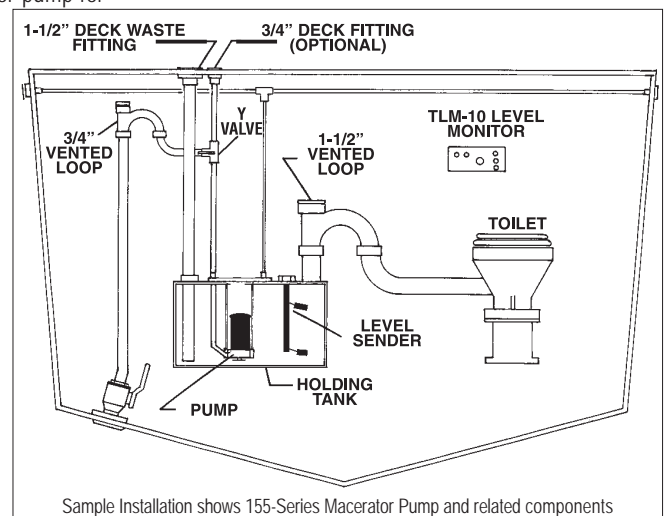
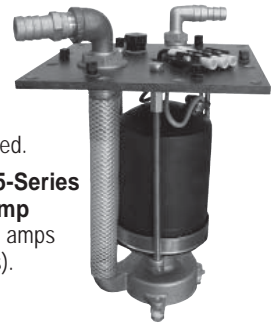

Sample Installation shows 155-Series Macerator Pump and related components

ITEM	PART NUMBER	PART NAME	QTY
1	BP-10-2	Grommet	1
2	99-0009-00	Pump Flange	1
3	99-0003-10	Discharge Assy	1
6	PTHC-5062	Vent Fitting	1
10	MP-726	Round Gasket	NLA
	01-0001-50	Square Gasket	1
11	SBP-204	Motor Boot	1
13	(Voltage)-S	Motor - Shaft - Screws	1
14	MP-725-(length)	Tie Rod	3
15	009-0375-00	Seal Assembly	1
16	MPS-600	Pump Casting	1
17	MP-603	Impeller	1
20	MP-601	Pump Cover	1
25	MP-727	Macerator Blade	1
NS	Snap Ring-2	Snap Ring	1

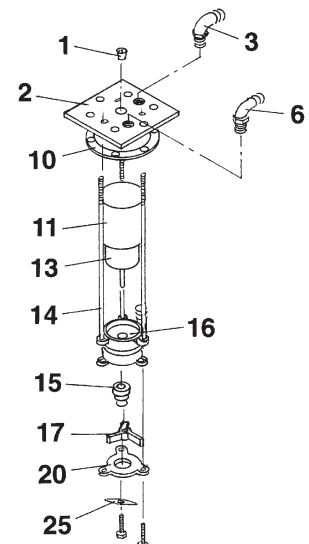

© 1999 GROCO MECHANICAL LABORATORIES, INC. ALL RIGHTS RESERVED.