

SA and ASA Series Strainers

Installation, Operation, and Maintenance

General Installation: Locate the strainer in a vertical orientation between the inlet seacock and the engine raw water pump in a location that will allow routine maintenance. Leave at least 12" above the top of the strainer for removal of the filter basket for cleaning.

Proper support is essential; install SA strainers with bolts through all three (3) bolt holes provided - two (2) on the strainer head and one (1) on the strainer base. Use the mount pads on both sides of the strainer if possible.

Bonding: The strainer must be connected to the vessel bonding system. This is most easily done with 14-gauge (or larger) stranded copper wire and a ring connector beneath one of the tie rods that hold the strainer together.

Warning: Motorized equipment is to have a separate connection to the vessel AC grounding bus in accordance with ABYC, E-11, Figure-18. DO NOT make the strainer bonding connection in series with motorized equipment. It is permissible to make the bonding connection in series with non-motorized equipment such as seacocks or thru-hull fittings.

Maintenance: Unscrew the center wingnut, and remove and clean the filter basket at least weekly. Inspect the cover gasket and plastic wingnut washer at this time. Replace the cover and screw down the center wingnut securely.

Important Maintenance Note: The sole purpose of the outside tie rods is to hold the strainer assembly together while the wingnut has been removed from the center tie rod for filter basket cleaning. If the sight glass gaskets are in serviceable condition they will seal by tightening the center tie rod only. Do not overtighten the outside tie rods in an attempt to seal leaking sight glass gaskets, as this may bend the strainer base casting - install a service kit.

Plumbing: As with any plumbing system, the components will function with greater efficiency when restrictions are kept to a minimum. When planning the plumbing for SA Series Strainers assure that 90-degree bends are utilized only when necessary and that hoses and fittings have as large an ID as possible. Use GROCO Full Flow fittings if you can.

Double clamp all hose connections and use TFE thread tape on threaded connections.

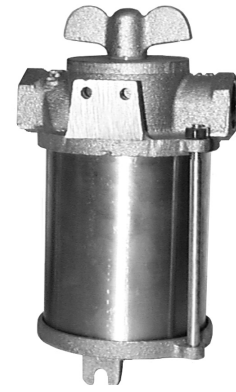

ASA Series has a #316 Stainless Steel Enclosure



SA Series has a Lucite Sight Glass

Parts and Assembly

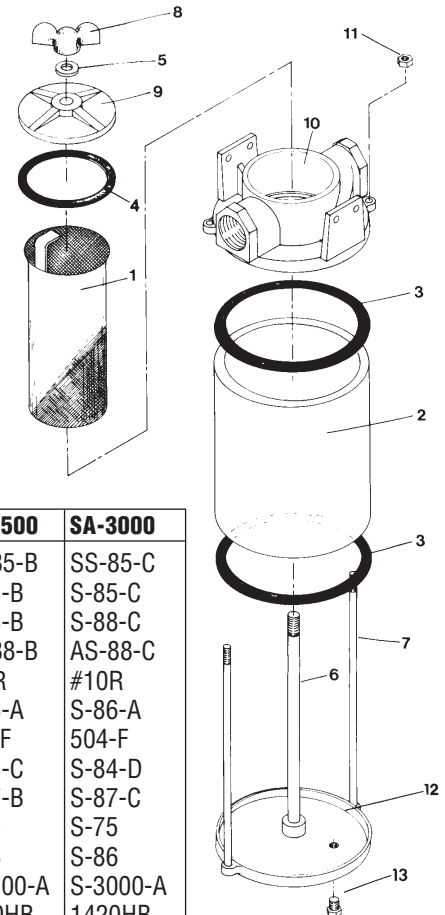

ITEM	DESCRIPTION	QTY	SA-500	SA-750	SA-1000	SA-1250	SA-1500	SA-2000	SA-2500	SA-3000
1	Basket, SS	1	SS-69	SS-69-A	SS-76	SS-76-A	SS-85-F	SS-85-A	SS-85-B	SS-85-C
	Basket, monel	1	S-69	S-69-A	S-76	S-76-A	S-85-F	S-85-A	S-85-B	S-85-C
2	Sight Glass	1	S-70	S-70-A	S-77	S-77-A	S-88	S-88-A	S-88-B	S-88-C
	Enclosure, SS	1	AS-70	AS-70-A	AS-77	AS-77-A	AS-88	AS-88-A	AS-88-B	AS-88-C
• 3	Gasket	2	#9R	#9R	#8R	#8R	#10R	#10R	#10R	#10R
• 4	Gasket	1	S-64-A	S-64-A	S-751-A	S-751-A	S-86-A	S-86-A	S-86-A	S-86-A
• 5	Washer	1	500-K	500-K	500-K	500-K	504-F	504-F	504-F	504-F
6	Tie Rod	1	S-65	S-65-A	S-72	S-72-A	S-84	S-84-A	S-84-C	S-84-D
7	Tie Rod	2	S-66	S-73-X	S-73-X	S-73-B	S-73-B	S-87-A	S-87-B	S-87-C
8	Wingnut	1	SVS-5	SVS-5	SVS-5	SVS-5	S-75	S-75	S-75	S-75
9	Cover	1	S-64	S-64	S-751	S-751	S-86	S-86	S-86	S-86
10	Head Casting	1	S-500-A	S-750-A	S-1000-A	S-1250-A	S-1500-A	S-2000-A	S-2500-A	S-3000-A
11	Hex Nut	2	1420HB	1420HB	1420HB	1420HB	1420HB	1420HB	1420HB	1420HB
12	End Cap	1	S-63-A	S-63-A	S-73-A	S-73-A	S-82-A	S-82-A	S-82-A	S-82-A
13	Drain Plug	1	1827HB	1827HB	1827HB	1827HB	1827HB	1827HB	1827HB	1827HB
•	Service Kit		SA-1	SA-1	SA-2	SA-2	SA-3	SA-3	SA-3	SA-3

© 1998 GROCO MECHANICAL LABORATORIES, INC. ALL RIGHTS RESERVED.