

**The Concept:** GROCO SV series seacocks were manufactured for the marine industry between 1960 and 1993. Production was discontinued in favor of the presently manufactured BV, SBV, and SBV-P series Full Flow Ball Valves.

SV series seacocks operate on the simple “expanding plug” principle. A wingnut on the back of each valve is hand-tightened when in the valve is in the desired open or closed position. Tightening the wingnut expands the rubber plug, thus sealing the valve.

**Operation:** When a change in valve position is desired, the wingnut is loosened enabling the operator to turn the valve handle to the new position. Re-tighten the wingnut each time.

Note: While the wingnut is loose the seepage of a small amount of water is normal.

**Maintenance:** Years of maintenance-free service can be expected. If the valve becomes difficult to turn, at haul-out remove and inspect the valve plug. The rubber should be free of bumps that might be created due to extended periods of non-use. (The pressure exerted by the tightened wingnut forces rubber into the drain plug hole and into the inlet and outlet ports, and older plugs do not quickly

return to their original shape). Bumps may be removed with light sanding. Replace plugs with excessive bumps.

**Lubrication:** Lubrication is not normally required, but may aid in the easy operation of older valves. Remove the valve plug and coat lightly with silicon based waterproof grease. Do not use petroleum based grease as it will chemically attack the rubber.

Some owners may prefer to replace the drain plug on the side of SV seacocks with a stainless steel grease zerk (the drain plug thread size for all SV seacocks is 1/8”-27 NPT) .

**Winterization:** Freezing will damage the seacock. To properly winterize the valve, move the handle to the closed position, and tighten the wingnut. Remove the drain plug on the side of the valve to drain the water from the valve body. Remove the hose or pipe at the top of the valve to drain the water from the connected plumbing.

**Upgrading:** Many boat owners prefer the simplified operation of GROCO BV, SBV, SBV-P or BVS series ball valves (No wingnuts to loosen and tighten, and no temporary water seepage). Your old SV series seacock may be replaced with a GROCO ball valve, Safety Seacock, or seacock/strainer combination.

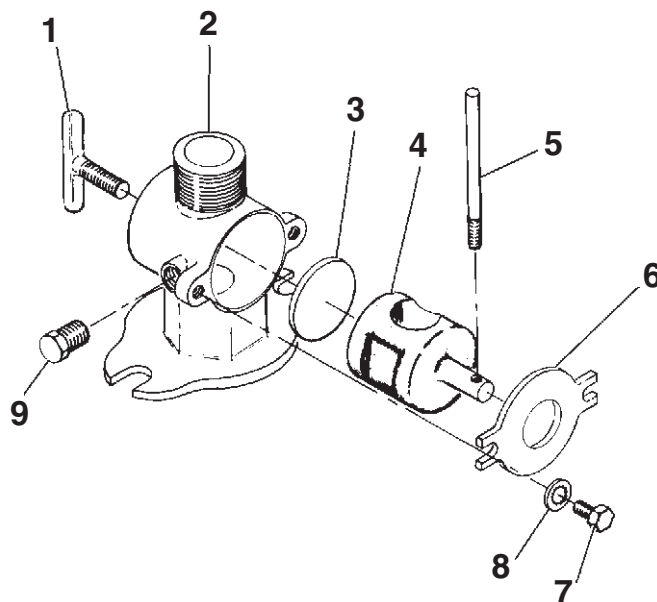

Item	Name	Qty	SV-500	SV-750	SV-1000	SV-1250	SV-1500	SV-2000	SV-2500
1	Wingnut	1	SV-502	SV-752	SV-752	SV-1502	SV-1502	SV-2502	SV-2502
2	Body	1	SV-500-B	SV-750-B	SV-1000-B	SV-1250-B	SV-1500-B	SV-2000-B	SV-2500-B
3	Disc	1	SV-503	SV-753	SV-103	SV-1252	SV-1503	SV-2003	SV-2503
4	Plug	1	SV-506	SV-756	SV-1006	SV-1256	SV-1506	SV-2006	SV-2506
5	Handle	1	SV-506-A	SV-756-A	SV-1006-A	SV-1256-A	SV-1506-A	SV-2006-A	SV-2506-A
6	Cover	1	SV-501	SV-751	SV-101	SV-1251	SV-1501	SV-2001	SV-2501
7	Bolt	2 or 4	1420X12HB	1420X12HB	1420X12HB	1420X12HB	1420X12HB	1420X12HB	1420X12HB
8	Lockwasher	2 or 4	14ETB	14ETB	14ETB	14ETB	14ETB	14ETB	14ETB
9	Drain Plug	1	1827HB	1827HB	1827HB	1827HB	1827HB	1827HB	1827HB